



PIV Air Source & PIV Inline

INSTALLATION AND USER GUIDE





Made in Harrogate
UK

Thank you for choosing EnviroVent

The fastest growing ventilation company in the UK.

You are about to install a product that is designed to outlast the life-cycle of the building. Once installed the unit will operate continuously for 5 years and beyond without a major service. Please therefore ensure that this product is treated with care and installed properly i.e. for the life of the building. If the unit is mishandled you might break it! This invalidates the warranty.

And remember, if you have any problems please call our dedicated Technical Team. We are always pleased to help and in an emergency will come out to site quickly, completely free of charge.

HOTLINE: 0845 27 27 810

PRE-INSTALLATION CHECKLIST

- 1 Check that the loft has adequate cross flow ventilation.
- 2 Check that all party walls are intact, seek advice if the wall is missing or broken.
- 3 Check that any flue which passes through the loft is not damaged, seek advice if the flue is in a poor state of repair.
- 4 Check for any flued appliance which may draw air from the loft, report to the client.
- 5 Check for any holes in the ceilings which may allow leakage of air to the loft and repair as appropriate.
- 6 Check that the water storage tank is covered.

IMPORTANT Smoke Detectors

It is important that any open side of the plastic diffuser is not positioned within 1m of a smoke detector. If the diffuser cannot be repositioned, up to two sides of the diffuser may be closed off using the plastic blanking plate supplied so that the open sides face a minimum 1.5m unobstructed path away from the detector.

SAFETY AND RECOMMENDATIONS

All wiring must comply with Building Regulations and the current I.E.E. Wiring Regulations (BS7671) or the equivalent standards for your country. The final installation should be examined and tested by a qualified electrician. This appliance is not intended for use by any person with reduced physical, sensory or mental capabilities, or lack of experience and knowledge, unless they have been given supervision or instruction concerning use of the appliance by a person responsible for their safety. Children should be supervised to ensure that they do not play with the appliance. If the supply cord is damaged, it must be replaced by the manufacturer, its service agent or similarly qualified persons in order to avoid a hazard.

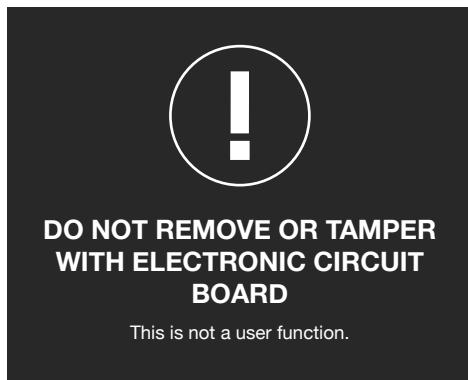
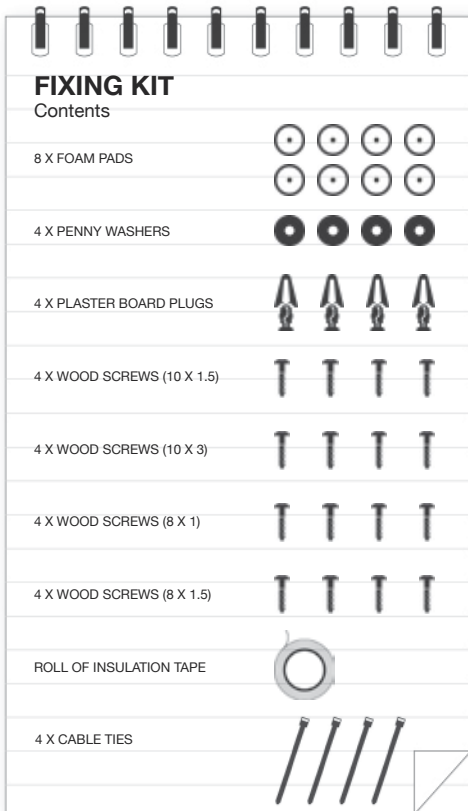

INSTALLATION DIAGRAMS

STANDARD INSTALLATION

Installation diagram for the EnviroVent PIV Air Source Unit

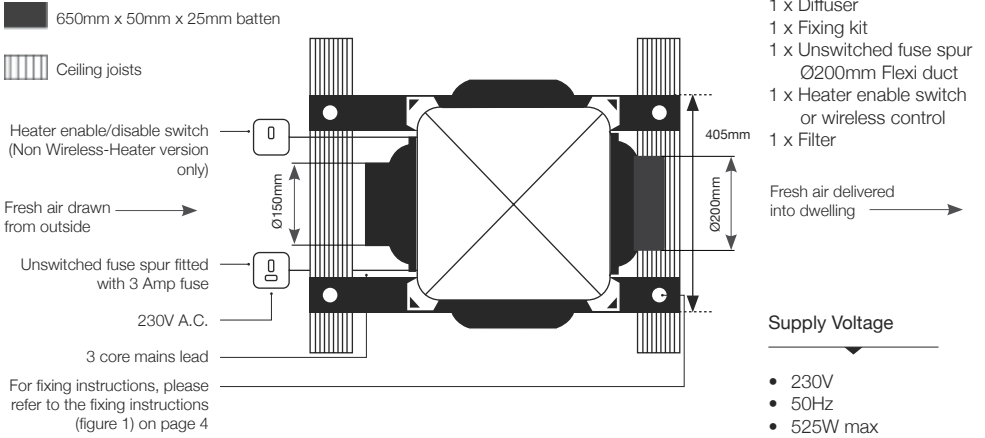

UNIT DIMENSIONS

Dimensions of the EnviroVent PIV Air Source

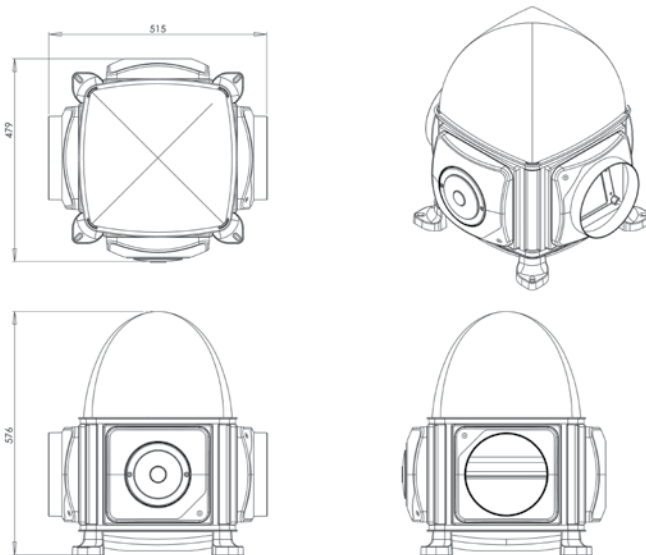

SHOULD YOU ENCOUNTER ANY PROBLEMS INSTALLING THIS UNIT CALL

☎ 0845 27 27 810

INSTALLATION INSTRUCTIONS

FIRST STAGE

Position a dustsheet beneath the site you have chosen for cutting the hole for the diffuser. Protect your lungs with a mask. Enter the loft space with the PIV Air Source or PIV Inline unit and check there are no obstructions to your chosen position for the diffuser. Using the template supplied mark the hole for the diffuser and cut the 220mm hole in the plasterboard.

N.B For installations in 3 storey dwellings, the unit should be linked to the dwellings smoke alarm system and fitted with a steel fire diffuser, part number: KIT-PIV-SMOKE.

Fig.1 Fixing Instructions

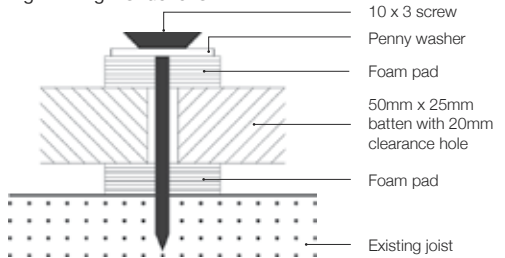

SECOND STAGE

Position the PIV Air Source or PIV Inline unit on 50mm x 25mm wooden battens (not supplied) laid across the joists or raised platform if the insulate is thicker than the joists so that the trunking between the unit and the diffuser is not impeded. Lightly screw the drilled battens to the joist through the rubber mounts and metal penny washer provided. Fit the trunking to the unit spigot using half of the tape provided.

THIRD STAGE

Push ducting through the hole in the ceiling. Return to the hallway and connect the ducting onto the neck of the diffuser using rest of the tape provided. Ensure that the diffuser is aligned correctly with the walls of the hallway. Adjust if necessary. Fix the diffuser in position using plasterboard plugs and the screws provided.

FOURTH STAGE

Fit the filter as per the diagram below (PIV Air Source only)

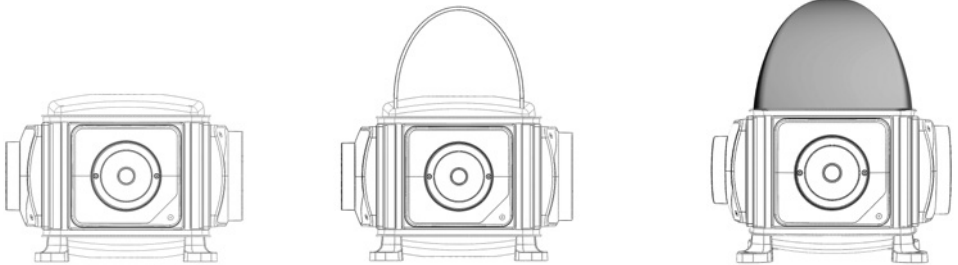

1. As soon as the unit is secured in desired location, place the filter on.

2. First locate the rods (provided) to support the filter.

3. Then velcro the filter into position.

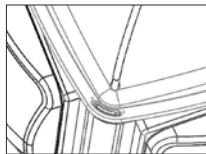

Detail

INSTALLATION INSTRUCTIONS

FIFTH STAGE - Fitting the inline filter

Filter location - The filter should be located in the supply airflow between the external input point and the Air Source Unit. It is recommended that it is fitted directly to the Loft Unit spigot in a section of $\text{Ø}150\text{mm} \times 350\text{mm}$ (min) ridged duct. See Fig.4.

Filter Orientation - The cone filter should always point towards the Air Source unit.

Fixing and sealing - The filter should be fully sealed into the ducting, however it should not be permanently bonded into position, this is to allow for removal of the filter during maintenance. Use a flexible section as shown in Fig 1 & Fig 4 to aid removal, 300mm is recommended. Always apply the label provided to the filter location, this is to assist future filter maintenance (Fig 3).

Installation configurations - For sample configurations see (Fig 2).

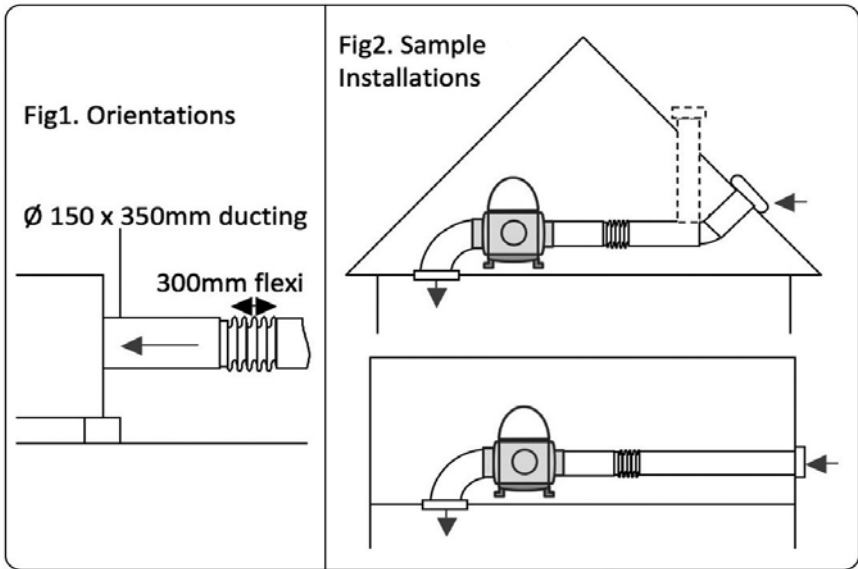

INSTALLATION INSTRUCTIONS

Maintenance - For maximum efficiency of the unit, it is recommended that the filter is cleaned every 24 to 36 months by a competent person. Use a vacuum cleaner, a soft brush or warm water (air dry fully before replacing).

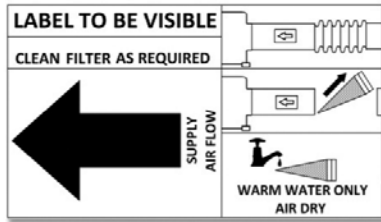
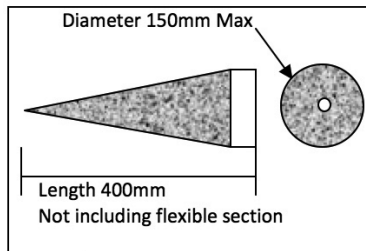

Fig 3.

Size



Filter Assembly

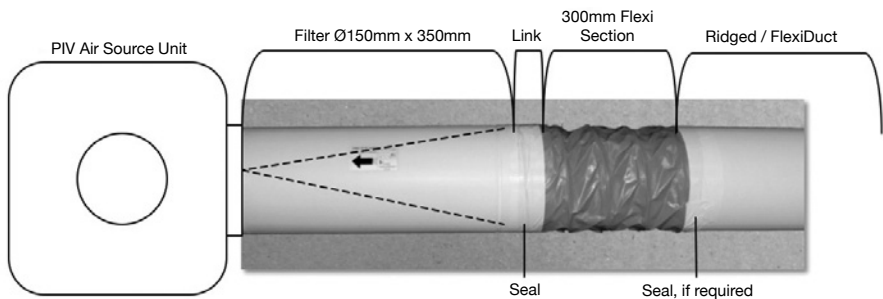

Fig 4.

INSTALLATION INSTRUCTIONS

SIXTH STAGE

Choose a location for the fresh air intake and drill a $\varnothing 158\text{mm}$ (or $\varnothing 132\text{mm}$) hole for wall kit. Depending on the layout of your attic, you have three options for locating the input of fresh air (wall input; roof input and under tiles input). If $\varnothing 125\text{mm}$ wall / roof kit is installed, use an $\varnothing 150\text{mm}$ adaptor to connect to the unit with $\varnothing 150\text{mm}$ insulated ducting. Make sure that all connections are sealed well.

It is recommend that $\varnothing 150$ intake vent is used for best performance

Delivering Fresh Air - Options

- ① Fresh air drawn from outside - Wall Input
- ② Fresh air drawn from outside - Under Tiles Input
- ③ Fresh air drawn from outside - Roof Input

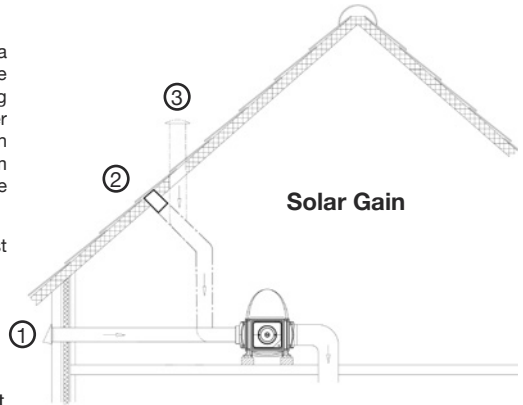

SEVENTH STAGE

The EnviroVent PIV Air Source and PIV Inline units must only be installed by a competent person and should be connected to an electrical supply in accordance with the current electrical regulations. A disconnection device should be used in the fixed wiring. Connect the heater enable cable to the switch provided (non wireless versions only).

EIGHTH STAGE

Check the unit is working correctly. Set the unit's controls according to the house size and check that the filters are securely in place.

NINTH STAGE - Manual settings

Method of operation: Adjust the settings on the top of the unit by pressing the house setting button. By pressing the button, the correct ventilation rate for the size of the house can be selected i.e. if the unit is on SMALL / TRICKLE and the button is pressed, the unit will then switch to MEDIUM. Similarly, if the unit is on BOOST and the button is pressed, the unit will then switch to SMALL / TRICKLE. The manual setting panel can be found on the side of the PIV Air Source unit and top of the PIV inline unit.

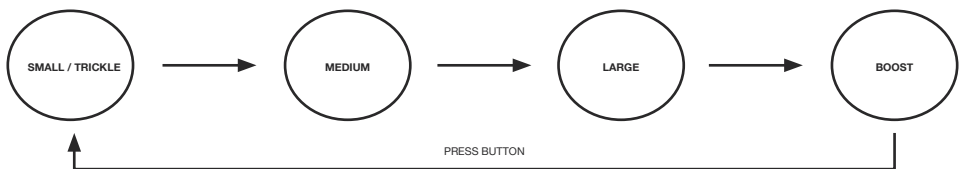

INSTALLATION INSTRUCTIONS

NINTH STAGE cont. - Wireless units only

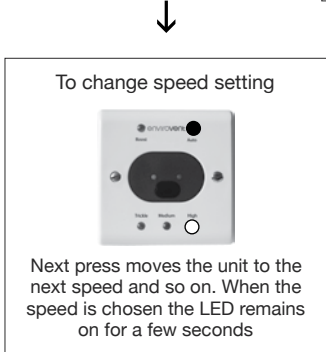
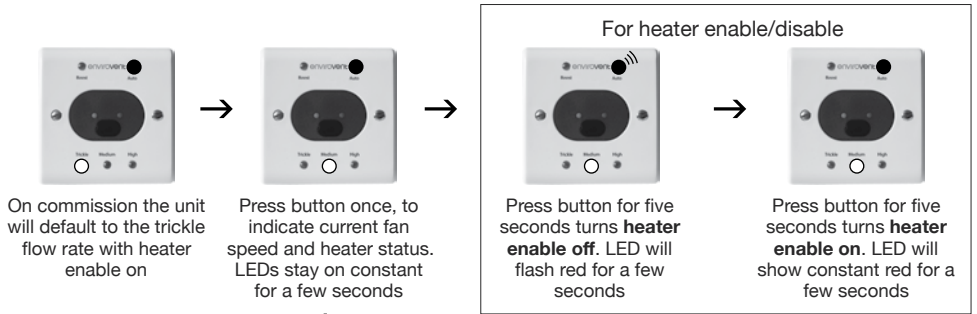

When the battery needs replacing, unscrew the front cover. The battery is located on the back of the cover. Battery type - 3V Lithium, CR2032

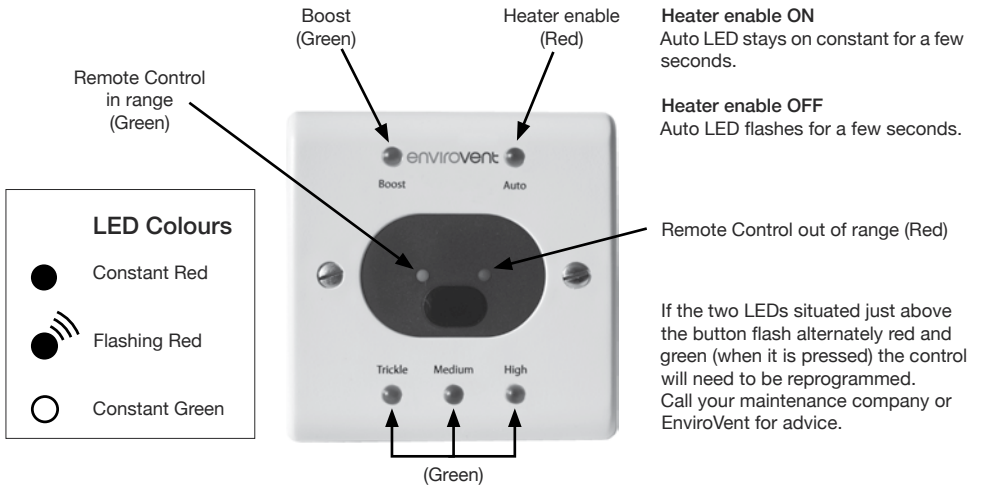

LED Colours

- Constant Red
- Flashing Red
- Constant Green

If the two LEDs situated just above the button flash alternately red and green (when it is pressed) the control will need to be reprogrammed. Call your maintenance company or EnviroVent for advice.



USER GUIDE
FOR RESIDENT

USER GUIDE

About your EnviroVent PIV Air Source & PIV Inline

DO YOU KNOW WHAT'S GOING ON IN YOUR OWN HOME?



MOISTURE

The typical household creates around 100 pints per week - from showers, baths, cooking etc.



CHEMICAL EMISSIONS

From everyday household furnishings, building products etc.



FUMES

From tobacco products, exhaust gases etc.



DUST

From furniture, carpets, bedding etc.

= Poor Air Quality = Condensation, Damp & Mould

THE CAUSE OF CONDENSATION, DAMP AND MOULD

In a dwelling of 4 people, each will contribute approximately 4 pints of moisture per day – through showers, boiling kettles, cooking etc totalling over 100 pints of liquid per week.

Other airborne contaminants which exist in a typical dwelling like dust, tobacco products, exhaust gases – even chemical emissions from furnishing and building products further deteriorate air quality.

In older, less energy efficient dwellings, there is a natural escape for this hot, damp problem air – through ill-fitting windows and doors, uncarpeted floorboards, lofts without insulation and so forth.

Improved building features such as cavity wall insulation, double-glazing and draft proofing prohibit 'natural ventilation'. Stale, humid air is trapped – increasing the condensation problem in the dwelling.

The Benefits

Say goodbye to condensation & mould

- Whole house ventilation
- Improved air quality
- Musty odours removed
- Streaming windows stopped
- Condensation control
- Enhanced heat distribution
- Benefits allergy and asthma sufferers

SHOULD YOU ENCOUNTER ANY PROBLEMS INSTALLING THIS UNIT CALL

 0845 27 27 810

How does my Loft Mounted Unit work?

The Loft Mounted Units work by supplying fresh, filtered air throughout the home to transform a stagnant and stale atmosphere into a fresh, healthy and condensation-free environment.

The units can deliver air into a home via a single input, usually located in a central landing.



PIV Air Source



PIV Inline

How does my Loft Mounted Unit help?

It prevents the build-up of moisture in the house, controlling steam/condensation during bathing and cooking to prevent the formation of black mould on walls, behind cupboards etc. It will also help to stop general dampness and musty smells caused by poor ventilation.

Energy Saving Benefits

Your Loft Units also help to save energy in the following ways:

Minimum Energy Consumption

- ✓ Using the latest technology, the units are powered by ultra-low watt motors to achieve low running costs.

Solar Gain

- ✓ The units* take maximum advantage of the benefits from solar gain within the loft space. This is the natural accumulation of heat from the sun on bright days. Temperatures in the loft are on average 3°C higher than outside, which results in a relative saving of around 150 Watts per day in an average modern family home. This equates to approximately 10% of annual heating costs.

Heat Distribution

- ✓ Warm air accumulates at ceiling level. This air can be up to 7°C higher than the internal air at ground level. By introducing an air supply from the loft space, the Loft Units help to redistribute heat around the home to further reduce heating costs.

No need to open windows

- ✓ To reduce humidity and condensation during the heating season, significant energy loss occurs by opening windows. The Loft Units provides fresh, filtered air to the home and reduces humidity without the need to open windows, saving energy and heat loss.

Health Benefits:

- ✓ Reduces mould spores, a trigger for respiratory problems and allergies
- ✓ Reduces house dust mite populations by lowering humidity levels - a main trigger for asthma and allergies

*except the Inline models

How do I control my Loft Unit?

The whisper quiet Loft Units operate continuously 24 hours a day. It is important that the unit is not turned off.

On auto the flow rate of the unit will be set at the appropriate level for your home during installation. To enable or disable the heater press the heater enable switch on or off.

Optional Wireless Switch Models

If you have a remote control switch you can change the unit flow rate/speed at any time at the push of a button. You can also use it to enable or disable the heater (see page 8 for operation instructions).

What features does my Loft Unit have?

The intelligent low temperature comfort heater* is designed to temper the air during periods of low external temperatures. It is capable of holding incoming air temperatures accurately at 10°C. With the function enabled, the heater may be on 10% of the time, depending on the fan speed setting and only at loft temperatures at or below 10°C. The units have an automatic increased airflow setting. This function increases airflow rates per setting by 10% to deliver additional air into the property at temperatures above 19°C.

*Heater may be omitted on request by the customer.

PIV Air Source only - Your unit is fitted with an automatic summer by-pass as standard. This switches the unit's airflow from the loft source to an atmospheric source when the temperature in the loft reaches 25°C. This is to avoid hot air being delivered into the property and maintains the correct level of ventilation at all times.

Maintenance

The Loft Units have been subjected to rigorous testing and are constructed from durable materials. There should be no requirement for any maintenance within the five year period.

PIV Air Source only - At the five year service, the loft filter located on the unit and the inline air source filter, located at the supply from atmosphere must be replaced to ensure maximum efficiency of the unit. The filter located on top of the unit is mounted with velcro, simply pull off and replace. The inline filter in the duct is located immediately before the unit. Release the duct and replace the cone filter. The duct must be reconnected and resealed.

PIV Inline only - At the five year service, the inline air source filter, located at the supply from atmosphere must be replaced to ensure maximum efficiency of the unit. The filter in the duct is located immediately before the unit. Release the duct and replace the cone filter. The duct must be reconnected and resealed.

Work to be carried out by a technically competent person to ensure safety and that the product continues to run efficiently. When carrying work out to this unit it should be isolated from the main power supply at the fuse spur

How much does my Loft Unit cost to run?

The Loft Units are very energy efficient. On a constant medium setting with the heater enabled, the unit will cost around £30* a year to run. With the heater disabled the unit will cost less than £6* a year.

*Based on an average electricity unit price of 15p.

Costs will vary year on year depending on atmospheric conditions and unit settings.

Helpful hints and tips

Keeping your home condensation free:

- Try to keep the house as warm as possible for as long as possible
- Do not dry clothes over any radiators
- Vent your tumble dryer outside
- Do not use paraffin / Calor gas type heating

Energy bills:

- To minimise energy bills you may need to adjust the central heating down if the input is in the same room as your thermostat.

SHOULD YOU ENCOUNTER ANY PROBLEMS INSTALLING THIS UNIT CALL

0845 27 27 810

WARRANTY CONDITIONS AND EXCLUSIONS

The EnviroVent Loft Mounted Units are covered by a 5 year warranty.

Do not turn your unit off. It is important that the unit runs continuously.

EnviroVent offer customers a full Supply and Fit service. This service also entitles our customers a unique 5 years parts and labour guarantee and if within the 5 years of installation the unit breaks down, we will repair it – FREE of charge.

Should you buy the fan from an approved wholesaler the product is protected by a 5 years parts guarantee and in the highly unlikely event of any problems you can call our helpline number or return it to the approved wholesaler.

Please note that proof of purchase by the way of a receipt is required and that any fans bought from an unapproved source, including but not limited to Ebay, will render the guarantee invalid.

What should I do if I have a problem?

If, after thoroughly reading this booklet, you feel that your unit is not working correctly, you can telephone the number shown at the bottom of this page (operational from 8:30am to 5:00pm Monday to Friday), and ask for technical assistance.

Serial number of the unit.....

We appreciate you choosing this quality EnviroVent product, which is designed and manufactured to the highest specification in Harrogate, North Yorkshire. We are confident that you will be delighted with the performance of the system and the resulting improvement in air quality in your home after the installation of the unit.

Your warranty covers any defect or break down that arises due to faulty materials or construction.

Terms of Warranty

- The system must be correctly installed and operated according to the instructions contained in the user guide supplied.
- Periodic cleaning and maintenance must be carried out by a technically competent person.
- The warranty will be rendered invalid if the unit is turned off. Turning the unit off can damage it.
- The warranty does not cover accidental damage, misuse or abuse.
- The warranty is in addition to your statutory or legal rights.
- The warranty will only be honoured from approved suppliers.
- A further 5 year warranty can be obtained subject to the level of service carried out at the 5 year point .



Delivering innovative and sustainable
ventilation solutions worldwide



 Please read carefully to ensure simple installation and a long trouble free life for the user.

AFTER INSTALLING THIS FAN PLEASE PASS ONTO END USER - DO NOT THROW AWAY

EnviroVent Ltd
EnviroVent House
Hornbeam Business Park
Harrogate
HG2 8PA

T 01423 810 810
F 01423 810 910
E info@envirovent.com

www.envirovent.com

E&OE | MKT ENV239-V4-28.03.14

Due to our policy of continuous innovation and improvement EnviroVent reserves the right to alter products specification and appearance without notice.