

envirovent®

# SILENT 100

Ultra Quiet WC & Bathroom Fans



# SILENT 100

Ultra Quiet WC & Bathroom Fans

CAN BE INSTALLED IN ZONE 1



## About

Range of 100mm domestic axial extract fans for wall or ceiling installations, designed to solve ventilation problems in WC's and bathrooms. Fitted with motors mounted on silent elastic blocks, the fans deliver incredibly silent running and exceptional performance with stylish features.

- Sealed for life ball bearings
- Silent elastic blocks
- IP45 rated
- SELV version - IP57 rated
- Backdraught shutter and airflow guide vanes as standard
- Available in silver
- 5 year warranty
- Quiet running
- High performance
- Pullcord option
- Significant energy savings
- Complies with local building regulations



## Optional Features

### Intelligent Timer



In automatic mode, the over-run timer calculates the amount of time to operate, depending on how long the fan has been running for. [Alternatively it can be manually set to 5, 20 or 30 minutes run-on time].

### Adjustable Timer



After disconnection, the shut off time can be delayed between 1 and 30 minutes.

### Adjustable Humidity Sensor



The level of humidity for the bathroom can be chosen from between 60% and 90% RH. The extract fan will continue to work long enough to reach the selected level.

### Pullcord



Supplied with pullcord override.

### PIR



Automatically starts up when the fan detects movement at a maximum of 4 metres.

## SELV



Connected to remote sited transformers supplied as standard [CT-12/14], [CT-12/14H] or with adjustable timer [CT-12/14R].

## Back draft shutter

To prevent air entry and limit heat leakage when the extractor is not operating. It opens due to the pressure of the air.



ORDER CODE	SIL 100 S	SIL 100 T	SIL 100 IT	SIL 100 HT	SIL 100 PIR	SIL 100 SS	SIL 100 ST	SIL 100 S 12V	SIL 100 T 12V	SIL 100 P 12V	SIL 100 TP 12V	SIL 100 HTP 12V
Pilot Light	•	•	•	•	•			•	•	•	•	•
Sealed For Life Ball Bearings	•	•	•	•	•	•	•	•	•	•	•	•
Silent Elastic Blocks	•	•	•	•	•	•	•	•	•	•	•	•
Backdraught Shutter	•	•	•	•	•	•	•	•	•	•	•	•
Adjustable Timer		•			•		•		•		•	•
Intelligent Timer			•									
Adjustable Humidity Sensor				•								•
PIR					•							
Pullcord										•	•	•
Silver						•	•					
SELV								•	•	•	•	•



## Numerous Quality Features

Fitted with pilot light, backdraught shutter and airflow guide vanes as standard to improve pressure development and performance, the SILENT range is also available with numerous quality features to include optional timer, humidity sensor, SELV and PIR models.



## Technical Specification

### Product

The SILENT 100 is an innovative domestic axial extract fan designed to offer a low level of noise supplied in a 230V or SELV (12V) format suitable for small rooms and bathrooms. The fan is fitted with a pilot light, backdraught shutter and airflow guide vanes as standard.

### Application Suitability

The SILENT 100 can be wall or ceiling mounted to meet the Building Regulations - Part F (England), Scottish Building Standards and Part K (Northern Ireland). The fan will ventilate domestic small rooms and bathrooms.

### Performance

MODEL ●	Silent 100 230V	Silent 100 12V
Speed (RPM)	2400	2320
Watts (W)	8	13
Voltage [V] 50Hz	230	12
Airflow l/s (m <sup>3</sup> /h)	26 (95)	26 (95)
dB(A) @ 3m	26.5	26.5
Weight (Kg)	0.57	0.57
IP Rating	IP45	IP57
∅ Duct (mm)	100	100

### Installation

Full installation guide is enclosed with all products; or sent separately in advance - if required.

### Motor

Is a 230V 50Hz or A/C motor, which is assembled on silent elastic blocks and fitted with ball bearings for enhanced working life.

### Fan

The impeller is axial flow type.

### Servicing / Maintenance

The extract fans only require periodical cleaning using a cloth soaked with a soft detergent.

### Warranty

The SILENT 100 is covered by a 5 year warranty.

### Compliance

CE Marked.

## Dimensions (mm)

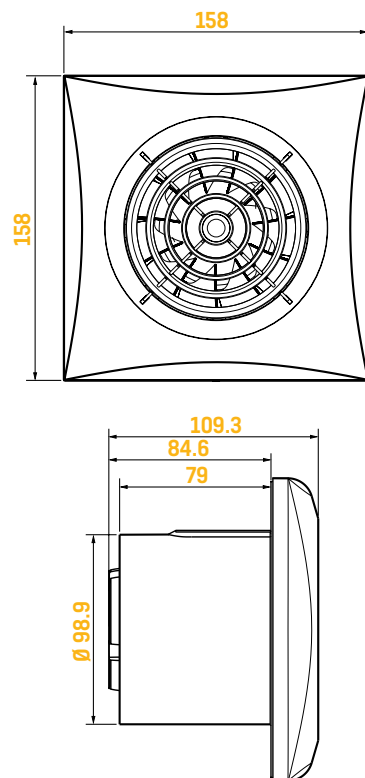

## Options & Ancillaries

DESCRIPTION	CODE(S)
STANDARD WALL KIT	1RDEFWAK100
FIXED LOUVRE GRILLE	1RDGRILL100
WINDOW KIT	SILWIK100
WINDOW KIT (FOR DOUBLE GLAZING)	WKDG100

## Performance Curve

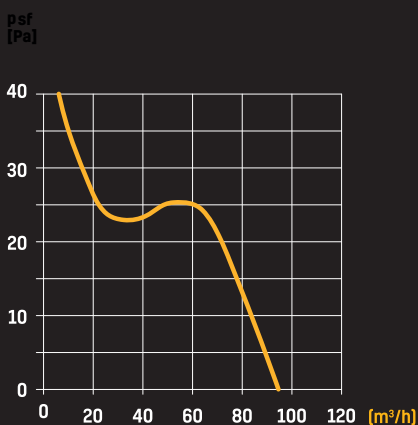

# envirovent®

Leaders in the manufacture of innovation and sustainable ventilation

EnviroVent Ltd  
EnviroVent House  
Hornbeam Business Park  
Harrogate  
HG2 8PA

T / 0345 27 27 807  
F / 01423 301 022  
E / enquiries@envirovent.com  
W / www.envirovent.com

Due to our policy of continuous innovation and improvement, EnviroVent reserves the right to alter products specification and appearance without notice.

E&OE | MKT ENV414 - V1 - 21.01.20

Copyright © EnviroVent Ltd 2020



Follow us on  
**facebook**



Follow us on  
**twitter**



Watch us on  
**Youtube**



Follow us on  
**Instagram**



Follow us on  
**Pinterest**



Find us on  
**LinkedIn**

