

TECHNICAL DATA SHEET PIV Loft | Whole House Positive Input Ventilation Unit



Lifetime Range*

PRODUCT

Whole house positive input ventilation system for properties with a loft space.

APPLICATIONS

The whole house PIV Loft Mounted unit shall be manufactured in the UK and installed in properties with a loft space to meet the Building Regulations Approved Document F.

SERVICING / MAINTENANCE

The unit shall have a maintenance free, five year warranty. Various service options are available towards the end of the end of the warranty period. The existing unit should remain in position to ensure minimal disruption to the occupier and no re-decoration is required. Any old components should be returned to the manufacturer for refurbishment/recycling. This ensures that no part of the unit should ever end up on a landfill site.

PERFORMANCE & SOUND LEVELS

Incoming Air Temp. [°C]	Fan Speed Setting	Specific Fan Power [SFP]	Airflow [l/s]	Power Usage [W] [4]	Outlet Noise dB(A) @3m
<19 (1) (2)	Trickle	0.17	21	4	<15
	Medium	0.15	29	4	<15
	Large	0.16	38	6	<15
	Boost	0.19	49	9	15

TECHNICAL DATA SHEET PIV Loft | Whole House Positive Input Ventilation Unit

INSTALLATION

Full installation guide is enclosed with all products; or sent separately in advance - if required. For fitment in 3 floor properties above 4.5m, EVL-H-W or EVL-W shall be fitted with a fire rated diffuser (contact EnviroVent for specific fire diffuser codes)

CONSTRUCTION

ABS plastic to contain at least 50% recycled material.

MOTOR

Incorporates the Ultra Low Watt DC motor technology with sealed for life ball bearings designed to operate continuously at a pre-set 'background' rate.

FAN

Is a 140 x 220mm centre mounted forward curved centrifugal fan.

FILTER

Is a synthetic fibre based filter made to ISO 65% (G4) standard in accordance with EN779 standard ratings, conforming to all European Union and US fire classification standards (e.g. DIN 53438-F1 and UL900-class 2) and be self-extinguishing.

SIZE (MM)

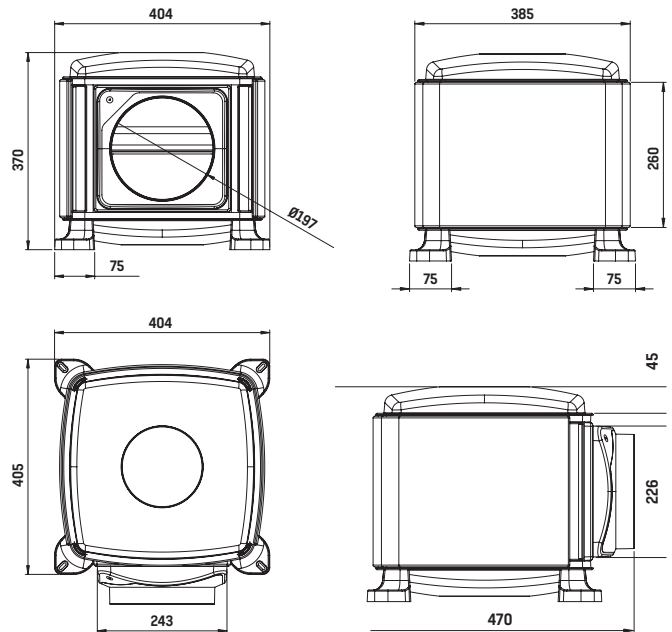

PERFORMANCE CURVE

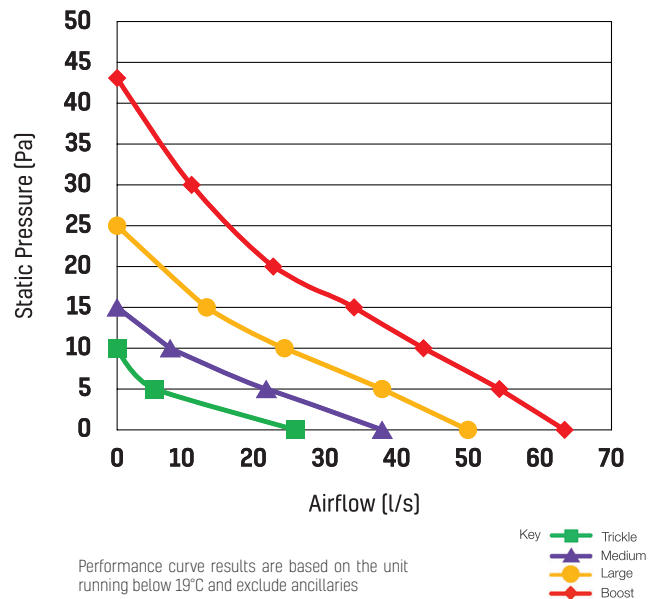

A full Consultant Specification can be sent on request.